

WIRELESS CALL BUTTON

Owner's Manual - LVA1074CAL

The Vive Wireless Call Button is designed to alert caregivers of patient needs with the press of a button. A wireless signal is sent to the pager. Caregivers can feel peace of mind that no matter where they are, their patients can reach them when they need assistance.

QUICK SET-UP GUIDE

Note: Wireless Pager sold separately.

Step 1:

Open the battery door of the Pager and insert two AA batteries as shown. Close the battery door.

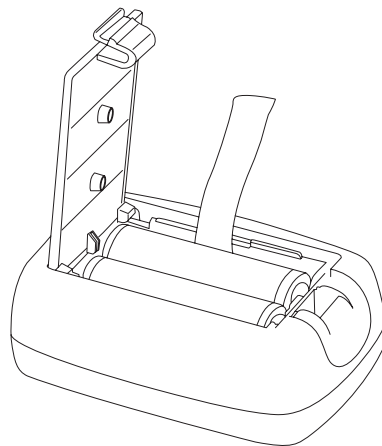

Step 2:

On the pager, press and hold both UP and DOWN arrows for 5 seconds. You will see the number "1" is blinking in red, indicating that the pager is now in programming mode.

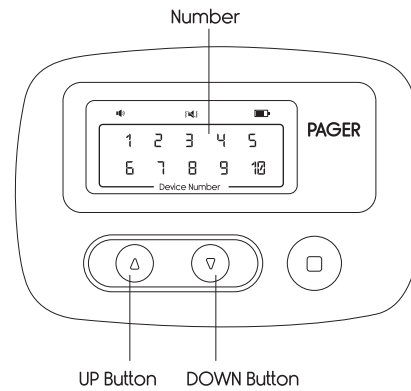

Step 3:

There are 10 channels on the pager for programming up to 10 individual wireless devices. Select a number for programming by pressing the UP or DOWN arrow on the front of the pager.

Step 4:

While the pager is in pairing mode, a red light should flash over the device number (#1-10) that you are attempting to pair the pager with. While this light is flashing press the button on the wireless call button. This will pair the devices.

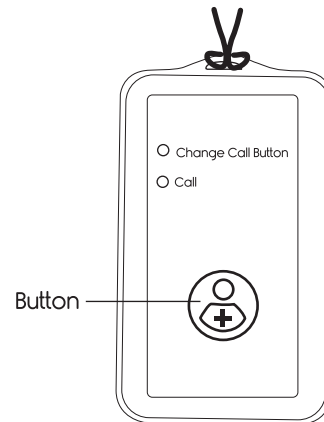

Step 5:

The pager will beep to signal a successful connection. Then it will re-enter programming mode in case you need to connect other wireless devices. If you do not need to connect more devices press and hold both the UP and DOWN arrows on the front of the pager to exit programming mode.

Note: When the alarm is triggered, the device number will flash on the Pager. To silence the pager, press the stop button. Repeat the steps above to program other wireless components to the same number or to the next number on the Pager if necessary.

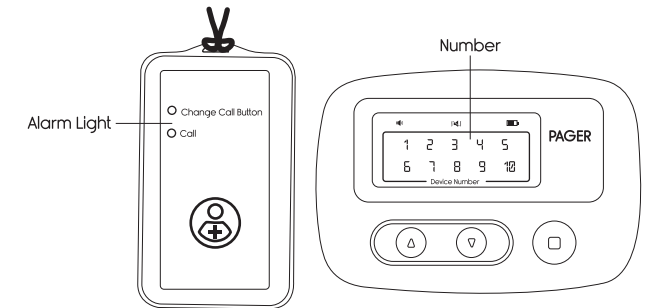

Step 6:

Set notification mode for the Pager. The Pager has three notification modes.

| Notification Mode | Notification | Sign |
|----------------------------------|-----------------------|------|
| Audible notification | Beeps | |
| Vibration notification | Vibration | |
| Audible + Vibration notification | Audible and Vibration | |

To set the notification modes, press and hold down both Button on the front of the Pager for more than 5 seconds until the image is blinking.

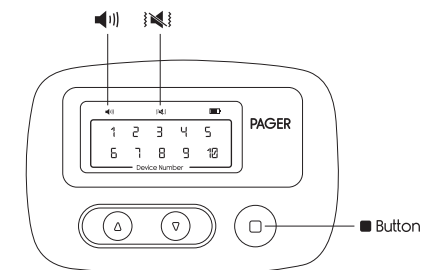

To select another notification mode, press and release the UP Button or DOWN Button on the front of the Pager. The next notification light will start blinking. Continue to press and release the Up or Down buttons until the desired notification light is selected. Once you've landed on your desired notification light, press and release the Button, you will hear a 1 second beep and/or feel a 1 second vibration. This means the current notification mode is recorded to the Pager.

Step 7:

Exit programming mode: Press and hold both the UP and Down buttons on the Pager for more than three seconds until you see the number light turn off. The Pager has now exited programming mode.

TEST THE WIRELESS CALL BUTTON

It is important to test the call button before using with a patient. To test, press the call button and release. If working correctly, the alarm light will flash one time and the programmed receiving devices will alarm. Press the button on the front of each receiving device to silence alarm.

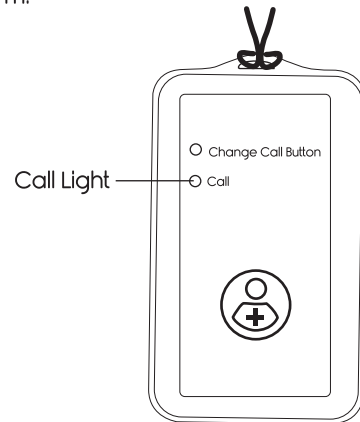

CHANGING THE CALL BUTTON

The usable life of this call button is 24 months. Actual life depends on how frequently the call button is used. When the call button needs replacing, the red "Change Call Button" light will flash.

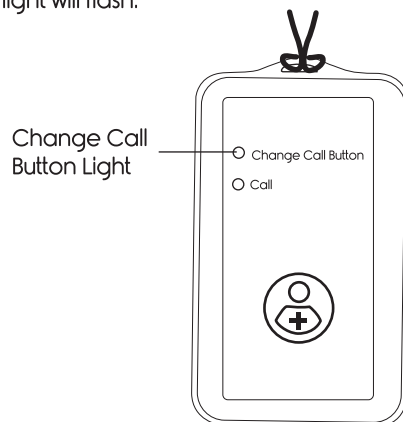

WARNINGS ⚠

- This device will not prevent a fall or injury. It is a supplemental part of an overall fall management program.
- Failure to follow all product instructions may result in the failure or improper function of the product.
- The Pager is able to communicate up to 150 feet away from the patient in open field. The actual communication distance or wireless range will vary from building to building. Test the wireless range in your building prior to putting the system into service. Always keep the pager located within the wireless range.
- The call button and any other devices should be checked prior to each use for proper functioning.

TROUBLESHOOTING

When your system is not properly functioning, please follow these steps.

Step 1: Change the transmitter if the "Change Alarm" light is lighted.

Step 2: Check on how long the Pager and transmitter have been in use. They may have run out of usual life.

Step 3: To determine which piece of equipment is at fault, follow the steps below:

- a. Take a new working transmitter and connect with the original Pager.
- b. If the system works properly, the problem is with the original transmitter.
- c. If the system still does not work properly, the problem is with the original Pager.